

MIRROR NATIONAL & EUROPEAN CHAMPIONSHIPS

POOLE YACHT CLUB

21st - 29th July 2006

SAILING INSTRUCTIONS

1.0 RULES

- 1.1 The regatta will be governed by the 'rules' as defined in the Racing Rules of Sailing, (2005-2008), the rules of the Mirror Class Association and these Sailing Instructions (SIs)
- 1.2 If there is a conflict between languages the English text will take precedence

2.0 NOTICES TO COMPETITORS

- 2.1 Notices to competitors will be posted on the official notice board(s) located inside the event marquee
- 2.2 The time and place of competitors briefings will be posted on the official notice board.

3.0 CHANGES TO SAILING INSTRUCTIONS

- 3.1 Any change to the SIs will be posted before 08:00 on the day it will take effect, except that any change to the schedule of races will be posted by 19:00 on the day before it will take effect.

4.0 SIGNALS MADE ASHORE

- 4.1 Signals made ashore will be displayed on the official flagpole on the eastern side of the Club House
- 4.2 When flag AP is displayed ashore 1 minute is replaced with not less than 30 minutes in the race signal AP
- 4.3 Flag R with a sound signal means 'The warning signal will be made not less than 30 minutes after flag R is displayed. No boat shall leave the slipway until flag R is flown with an accompanying sound signal. The flag will be displayed on a flag pole adjacent to the slipway.

5.0 SCHEDULE OF RACES AND BRIEFINGS

- 5.1 Briefings will be held as follows

| Date | Race Management | Safety Fleet | Competitor |
|---------------------------------|-----------------|--------------|------------|
| Saturday 22 nd July | 0800 | 0830 | 1000 |
| Sunday 23 rd July | 0800 | 0830 | 0845 |
| Tuesday 25 th July | 0800 | 0830 | 0845 |
| Wednesday 26 th July | 0800 | 0830 | 0845 |
| Thursday 27 th July | 0800 | 0830 | 0845 |
| Friday 28 th July | 0800 | 0830 | 0845 |
| Saturday 29 th July | 0800 | 0830 | 0845 |

- 5.2 Race Management meetings will be held in the committee room located on the first floor of the Club House. Safety fleet briefings will be held in the boat shed at the eastern end of the Club site. Competitors briefings will be held on the haven side of the main club house building

- 5.3 To provide the best possible chance of achieving the required number of races for both the Nationals and Europeans, 4 races which may be sailed back to back, will be scheduled each day, with the exception of Monday 24th July when there will be no races scheduled. However no more than 6 races in total will be sailed for the National Championships and no more than 12 races in total will be sailed for the European Championships.
- 5.4 The numbers of races scheduled is as follows:

| Date | Event | No of Races scheduled | Preparatory Signal for 1st Race of the Day |
|---------------------------------|--------------|------------------------------|--|
| Saturday 22 nd July | Nationals | 4 | 1155 |
| Sunday 23 rd July | Nationals | 4 | 0955 |
| Tuesday 25 th July | Europeans | 4 | 0955 |
| Wednesday 26 th July | Europeans | 4 | 0955 |
| Thursday 27 th July | Europeans | 4 | 0955 |
| Friday 28 th July | Europeans | 4 | 0955 |
| Saturday 29 th July | Europeans | 4 | 0955 |

- 5.5 When more than one race will be held on the same day, the warning signal for each succeeding race will be made as soon as practicable. To alert boats that another race or sequence of races will begin soon, the postponement signal will be displayed for at least 4 minutes before a warning signal is displayed.
- 5.6 During the National Championships the Championship Fleet will start each race before any single handed or bronze fleet start sequences are commenced..
- 5.8 On the last day of the National Championships, Sunday 23rd July, no warning signal will be made after 1600. On the last day of the European Championships, Saturday 29th July, no warning signal will be made after 1400.

6.0 CLASS FLAGS

- 6.1 The Class Flag to be used for the Nationals and European Championship fleets will be the numeral pennant 6. Should a single handed or bronze fleet be sailed as part of the National Championships the flag M will be used as their warning flag

7.0 RACING AREAS

- 7.1 Attachment “B” shows the location of the racing areas
- 7.2 Racing will be held in the top triangle of Poole Harbour to the South of the Poole Yacht Club. Depending on the weather, racing may also be in Bournemouth Bay on some days. The area to be used each day will be indicated at the competitors briefing

8.0 COURSES

- 8.1 The diagrams in Attachment ”A “show the arrangement of buoys and courses,
- 8.2 No later than the warning signal, the race committee signal boat will display the course to be sailed, the number of laps if appropriate and, if possible, the approximate compass bearing from the Committee Boat to Mark 1.

9.0 MARKS

- 9.1 Marks will be orange cylindrical buoys
- 9.2 The Committee Boat will be a yacht, “White Satin”

10.0 THE START

- 10.1 Races will be started by using rule 26, with the warning signal given 5 minutes before the starting signal.

- 10.2 The start line will be between a mast displaying an orange flag on the committee boat at the starboard end and a boat displaying an orange flag at the port end of the line.
- 10.3 Boats whose warning signal has not been made shall avoid the starting area
- 10.4 When during a start sequence a race is postponed and subsequently restarted, the warning signal will be hoisted one minute after the lowering of the AP signal
- 10.5 A boat starting later than 5 minutes after her starting signal will be scored Did Not Start. This changes rule A 4.

11.0 CHANGE OF THE NEXT LEG OF THE COURSE

- 11.1 To change the next leg of the course, the race committee will move the original mark (or the finishing line) to a new position or will lay a new mark and remove the original as soon as practicable will be in accordance with rule 33(a)(2).

12.0 SHORTENING COURSE

- 12.1 The race committee may shorten course by displaying flag S and two sound signals;
 - a. From the committee boat- boats are to finish at the committee boat
 - b. From an official RIB or other committee boat- boats are to finish between the RIB or other committee boat flying a blue flag and the adjacent turning mark.

13.0 THE FINISH

- 13.1 The finishing line will be between a mast on a committee boat displaying a blue flag, and a boat displaying a blue flag.
- 13.2 Any boat that is still racing 20 minutes after the first boat has finished may be finished at any point of the course

14.0 PENALTY SYSTEM

- 14.1 A boat that has taken a penalty under rule 31.2 or 44.1 shall complete an acknowledgement form at the race office within the protest time limit

15.0 TIME LIMITS

- 15.1 The time limits and target times for the first boat are as follows:

| Event | Race target time for lead boat | Time limit for race |
|-----------------------|--------------------------------|---------------------|
| National Championship | 45 minutes | 75 minutes |
| European Championship | 60 minutes | 90 minutes |

There shall be no grounds for redress under rule 62 if these timings vary

- 15.2 If no boat has passed Mark 1 within 30 minutes, the race will be abandoned

16.0 PROTESTS AND REQUESTS FOR REDRESS

- 16.1 An International Jury is appointed for the European Championships, from whose decisions there will be no right of appeal.
- 16.2 Action will be taken on the water by the protest committee / international jury under appendix P – Immediate Penalties for Breaking of Rule 42 – which is amended in that rule P2.3 is deleted, and that rule P2.2 shall apply to the second and subsequent protests.
- 16.3 Protest forms will be available at the Race Office. Protests shall be delivered within the protest time limit.

- 16.4 The protest time limit is 60 minutes after the last boat has hit the shore following the last race of the day. The same protest time limit applies to all protests by the race committee and protest committee / jury and to requests for redress.
- 16.5 Notices will be posted within 30 minutes of the protest time limit to inform competitors of hearings in which they are parties or named as witnesses. Hearings may be earlier than the advertised time if all parties are present. Hearings will be held in the Protest Room located on the first floor of the Club House.
- 16.6 Notices of protests by the race committee or protest committee / international jury will be posted to inform boats under rule 61.1(b).
- 16.7 Boats observed by the race committee not to have sailed the correct course will be scored DNF without the need to protest. Boats may seek redress from this action. This alters rule 63.1
- 16.8 No measurement protests will be accepted after protest time on the first day of each event if it was obvious at that time that a boat had broken a measurement rule.
- 16.9 The protest committee / international jury will implement an arbitration system if it is at all possible. Details, including appropriate penalties will be displayed on the Official Notice Board.
- 16.10 On the last day of either event a request for reopening a hearing shall be made no later than 30 minutes after the party requesting the reopening was informed of the decision on that day. This changes rule 66.

17.0 SCORING

- 17.1 The ISAF Low Points Scoring System of Appendix A4.1 will apply
- 17.2 The following number of races are required to constitute a series:

| Event | No. of races required to constitute a series |
|-----------------------|--|
| National Championship | 4 |
| European Championship | 6 |

- 17.3 No of races to count will be as follows:

| Event | 1 st discard applied | 2 nd discard applied |
|-----------------------|---------------------------------|---------------------------------|
| National Championship | Race 5 | N/A |
| European Championship | Race 6 | Race 10 |

18.0 SAFETY REGULATIONS

- 18.1 All competitors and safety personnel shall wear life jackets or other adequate personal buoyancy at all times when afloat. Wet suits and dry suits are not adequate personal buoyancy.
- 18.2 All helms and crew will tally out and in. Failure to do so will incur a £10 penalty fee payable to the RNLI.
- 18.3 A boat that retires from a race shall notify the race committee as soon as possible.
- 18.4 All competitors, support boats and official boats will not enter the area of the cross channel ferry turning circle. A safety boat will be on duty to ensure that this instruction is carried out.
- 18.5 All boats shall have an 8m tow line fitted securely with a metal caribena suitable for attaching to an 8mm line to facilitate the towing of boats to and from the race area.

19.0 REPLACEMENT OF CREW OR EQUIPMENT

- 19.1 Substitution of competitors will not be allowed without prior written approval of the race committee
- 19.2 Substitution of damaged or lost equipment will not be allowed unless approved by the race committee. Requests for substitution shall be made to the race committee at the first reasonable opportunity

20.0 EQUIPMENT AND MEASUREMENT CHECKS

A boat or equipment may be inspected at any time for compliance with the class rules and sailing instructions.

21.0 OFFICIAL BOATS

21.1 Official boats will be marked as follows.

| Role | Colour | Identification |
|--------------------------------|--------|------------------|
| Primary Safety | ORANGE | Numbers |
| Coach Boats / secondary safety | GREEN | Numbers |
| Judge | WHITE | "JURY" |
| Mark Layer | YELLOW | Numbers |
| Safety Officer | WHITE | "SAFETY OFFICER" |

21.2 The crews of all official boats and committee boat are designated members of the race committee

22.0 SUPPORT BOATS

22.1 Team leaders, coaches, and other support personnel shall stay 100m outside areas where boats are racing from the time of the preparatory signal for the first class to start until all boats have finished or the race committee signals a postponement, general recall or abandonment. Any boat which enters this area unless asked to do so by the race committee, will be required to donate £10 to the RNLI.

23.0 RADIO COMMUNICATION

23.1 A boat shall neither make radio transmissions while racing nor receive radio communications not available to all boats. This restriction also applies to mobile phones

24.0 PRIZES

- 24.1 Prizes will be presented as soon as possible after the last race of each Championship. The time and place will be posted on the official notice board.
- 24.2 The following prizes and trophies will be presented:

European Championship

| Prize or Trophy | Presented to |
|--------------------------|-------------------------------------|
| Daily Mirror Trophy | Overall winner helm |
| The Troon Quaich | Overall winner crew |
| British Rail Trophy 1 | Winner Day 1 |
| British Rail Trophy 2 | Winner Day 2 |
| British Rail Trophy 3 | Winner Day 3 |
| British Rail Trophy 4 | Winner Day 4 |
| British Rail Trophy 5 | Winner Day 5 |
| Visitors Trophy | First non Host Country |
| The Kerjouano | First from Host Country |
| The Troon Traveller | First Furthest travelled competitor |
| Waterford Wedgewood Bowl | First Lady Helm |
| Best Dutch Team Trophy | Best Dutch Team |

National Championship

| Prize or Trophy | Presented to |
|---|--|
| Daily Mirror | 1st Overall Helm |
| Crews | 1st Overall Crew |
| Pioneer | 2nd Overall |
| America's | 3rd Overall |
| Marlow Plate | Winners Race 1 |
| Cassandra's Cauldron | Winners Race 2 |
| Jeckell's Trophy | Winners Race 3 |
| Peter Wilson | Winners Race 4 |
| City of Plymouth | Winners Race 5 |
| National Westminster | Winners Race 6 |
| Abersoch Trophy | Winners Race 7 |
| 40 Anniversary Trophy | Winners Race 8 |
| Western Trust and Savings | Crew's Race |
| Arthur Birt | 1st Local Cadet Helm |
| Proops Pot | 1st Lady Helm |
| Arthur Viner | 1st Helm & Crew U19, other than overall champion |
| H Yule-Smith Plate | 1st Helm & Crew U15, other than overall or U19 winners |
| Team Shield | Best club (from results of 3 boats) |
| Aberdeen | 1st Scottish Boat |
| Gulf Oil | 1st Welsh Boat |
| Lucas | 1st Helm over 39 |
| 1963 | 1st Helm over 50 |
| Shavian Mug | Last on points having completed all races |
| Topaz | 1st Parent and Offspring |
| Bass Charrington | <i>1st Single Handed Race</i> |
| Super Crew | Youngest Crew to complete all races |
| Dyno-Rod | 1st Devon and Cornwall U18 Boat |
| Silver Jubilee (Original large trophy missing, Pewter jug substituted in 2002 or earlier) | 25th Overall |
| Jan Grieg-Gran Plate | Winner Silver Fleet |
| Jan Grieg-Gran Plate | Winner Bronze Fleet |

25.0 DISCLAIMER OF LIABILITY

25.1 Competitors participate in the regatta entirely at their own risk. See rule 4, Decision to Race. The organising authority and Class Association will not accept any liability for material damage or personal injury or death sustained in conjunction with or prior to, during, or after the regatta.

25.2 A boat is entirely responsible for her own safety, whether at sea or in harbour, and nothing, whether in the Notice of Series or the Sailing Instructions or anywhere else, reduces this responsibility. It is for the boat to decide whether she is fit to sail in the conditions in which she will find herself. By going to sea, the boat confirms that she is fit for those conditions and that her crew is competent to sail and compete in them.

25.3 Nothing done by the organisers can reduce the responsibility of the boat nor will make the organisers responsible for any loss, damage, death or personal injury, however it may have occurred, as a result of the boat taking part in the racing. The

organisers encompass everyone helping to run the race and the event, and include the organizing authority, the race committee, the race officer, patrol boats and beach masters.

26.0 INSURANCE

26.1 Each participating boat shall be insured with valid third party liability insurance with a minimum cover of £2,000,000 per incident or the equivalent.

27.0 TIDES

| Date | High Water | Low Water | High Water |
|---------------------------------|-------------|-------------|-------------|
| Friday 21 st July | 1016 (1.8m) | 1353 (1.1m) | 2025 (1.9m) |
| Saturday 22 nd July | 0843 (1.8m) | 1459 (1.1m) | 2100 (1.9m) |
| Sunday 23 rd July | 0926 (1.8m) | 1556 (1.0m) | 2127 (2.0m) |
| Monday 24 th July | 1001 (1.9m) | 1644 (1.0m) | 1345 (1.9m) |
| Tuesday 25 th July | 1029 (2.0m) | 1728 (0.9m) | 1433(1.9m) |
| Wednesday 26 th July | 1054 (2.0m) | 1807 (0.9m) | 1514 (1.9m) |
| Thursday 27 th July | 1123 (2.1m) | 1844 (0.9m) | 1550 (1.8m) |
| Friday 28 th July | 1157 (2.1m) | 1918 (0.9m) | 1621 (1.8m) |
| Saturday 29 th July | 1228 (2.0m) | 0731 (0.6m) | 1651 (1.8m) |

All times are local, BST is applied

28.0 JIB NUMBERS

28.1 All boats to display jib numbers, as follows :
 Outside edge of numbers to be 7 cm from luff
 Bottom edge of port side numbers to be 60cm from tack/foot
 Starboard numbers to be higher
 Numbers to be vertically orientated
 Distance between top and bottom of numbers to be 4 cm

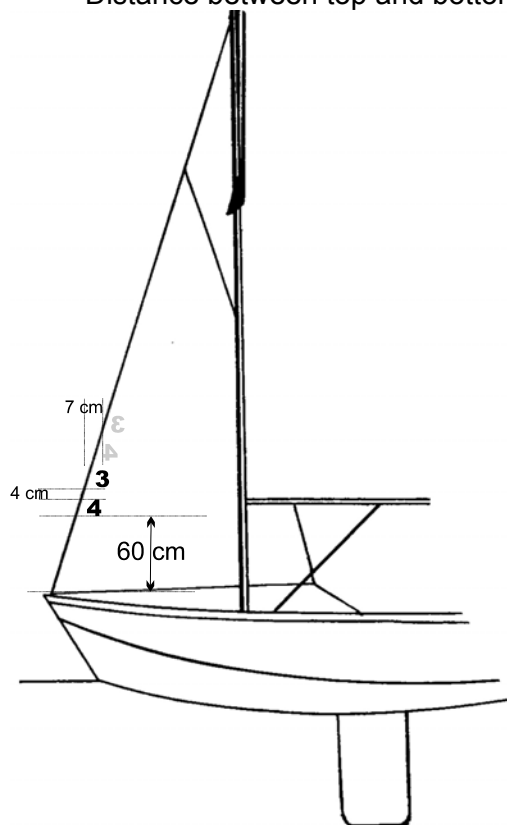

END OF SAILING INSTRUCTIONS

ATTACHMENT A – COURSES

Course A (First Start)

Per Lap:
Start, 1P, 2P, 3P, 2P, 3P, 5P, Start Line.

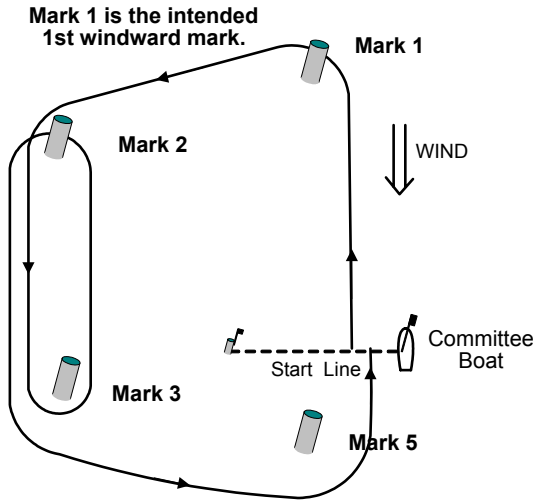

Course A (Second Start)

Per Lap:
Start, 1P, 4P, 1P, 2P, 3P, 5P, Start Line.

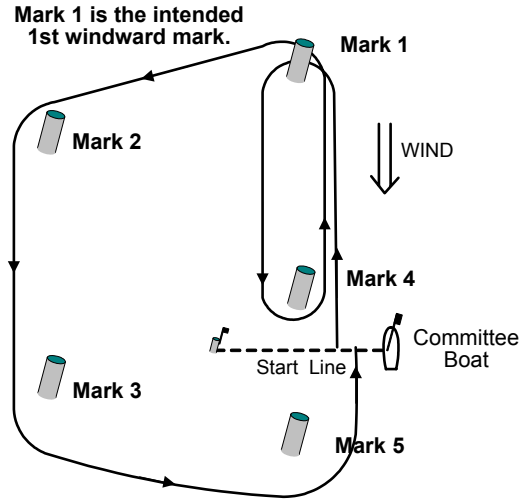

Course B

Start, 1P, 2P, 3P, 1P, 3P,
1P, 2P, 3P, 1P, 3P,
Finish Line.

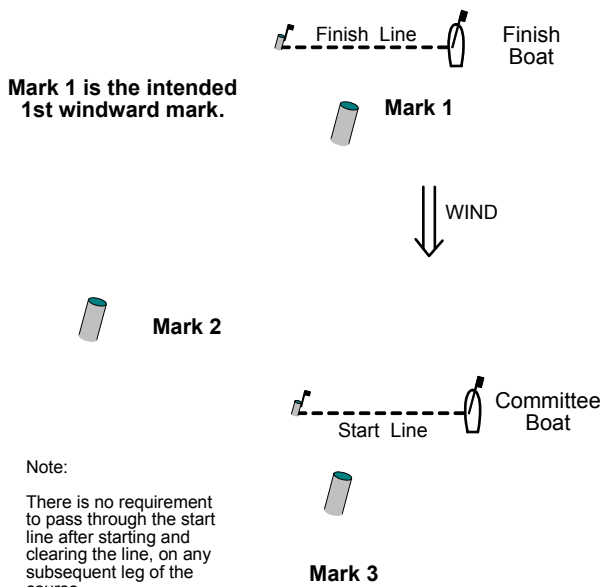

Course C

Per Lap:
Start, 1P, Leeward Gate, Start Line.

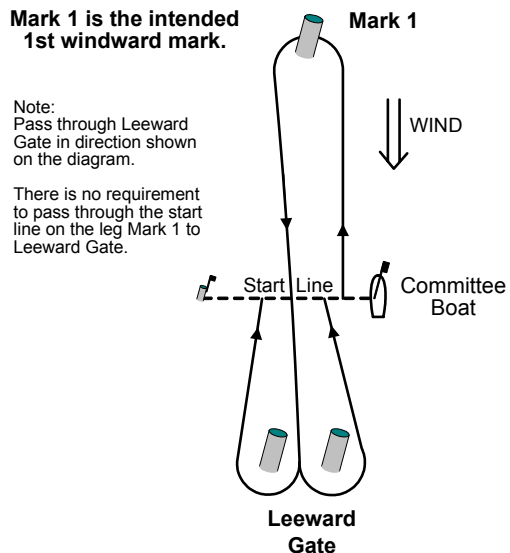

ATTACHMENT B – SAILING AREA

